

## ***Install Training Wheels***

For the assembly of the training wheels for 16in bike, please follow the instruction below:

1. Attach the training wheel to training wheel bracket.

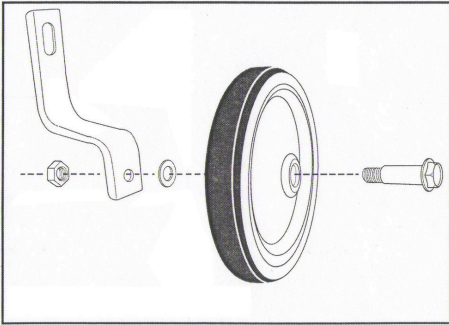

2. Remove the outside nut on both sides of the rear axle. Do not loosen or adjust the inner nuts on the axle.

3. Insert the training wheel bracket into the stabilizer bracket lining up the holes. Attach stabilizer and training wheel brackets on the axle as shown. Secure with nut and tighten.



stabilizer bracket

3. Both training wheels should be with a distance of 1-1.5cm to the ground when the bike is balanced on its wheels.

